

Chapter 2

Ohm's law

Ohm's Law

The voltage across a resistor is directly proportional to the current flowing through it.

- Ohm's Law may also be expressed as

$$E = IR \quad (\text{volts, } V)$$

$$R = \frac{E}{I} \quad (\text{ohms, } \Omega)$$

- For a fixed resistance, doubling the voltage doubles the current.
- For a fixed voltage, doubling the resistance halves the current.

Ohm's Law & Voltage Symbols

- For voltage sources, use uppercase E .
- For load voltages, all voltage drops across components of the network the uppercase V is applied.
- Both symbols can be applied in any equation for single sources
- For AC voltages use lowercase e.g. v

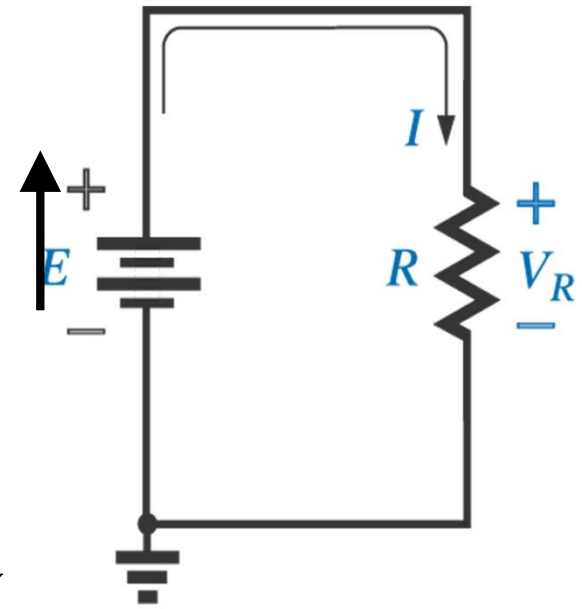

$$I = \frac{V_R}{R} = \frac{E}{R}$$

$$R = \rho \frac{l}{A} \text{ for the resistor}$$

Current Direction & reference arrow

- We normally show current out of the positive terminal of a source.
- If the actual current is in the direction of its reference arrow, it will have a positive value.
- If the actual current is opposite to its reference arrow, it will have a negative value.
- Conventional current is employed (opposite direction to electron flow)

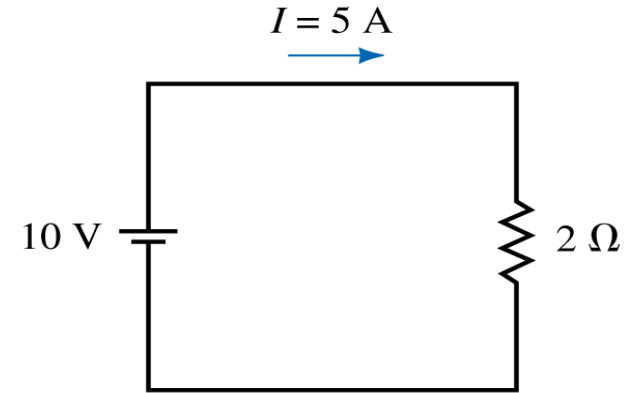

(a)

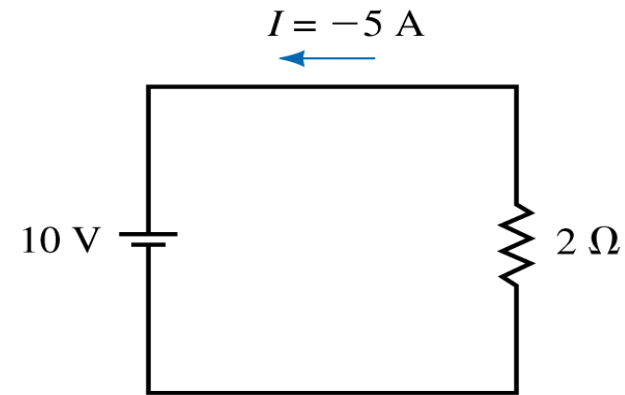

(b)

Voltage Polarities

- The effect of more than one source in the same network must be investigated.
- The drop voltage direction is opposite to the direction of current flow (extremely important)
- The current enters the positive terminal and leaves the negative terminals for the load resistance R

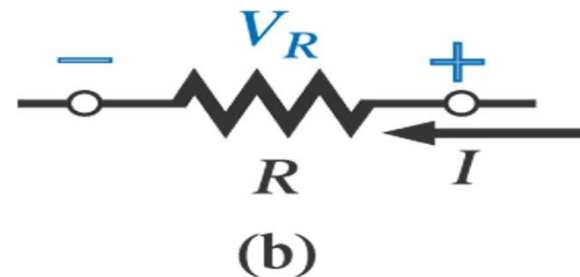
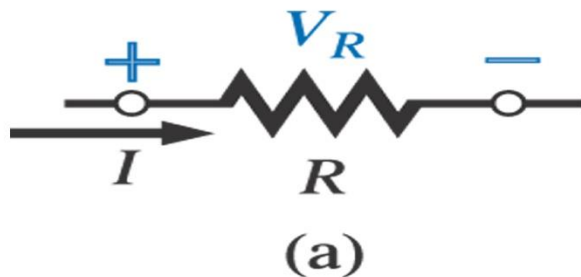

Place the plus sign of voltage at the tail of the current arrow

EX & H.W

-Find the current resulting from the application of a 9 V battery across a network with a resistance of 2.2Ω

$$I = \frac{V_R}{R} = \frac{E}{R} = \frac{9V}{2.2\Omega} = 4.09A$$

-What is the current, if a lamp has resistance of 96Ω and battery is 12 V
 $I = 12V/96\Omega = 0.125A = 125 \times 10^{-3}A = 125mA$

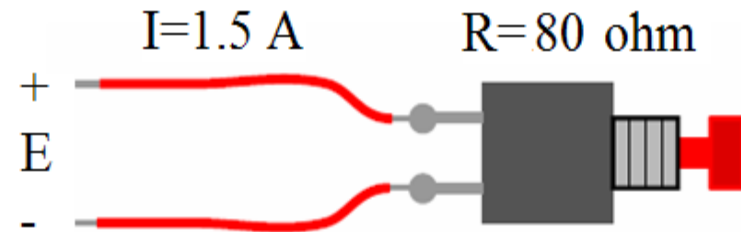

- H.W: Find the voltage that must be applied across the soldering iron to establish a current of 1.5 A through the iron if its internal R is 80Ω



Plotting Ohm's Law

The relationship between current and voltage is linear.

$$y = mx + b$$

$$y = I$$

$$m = 1/R$$

$$x = E$$

$$b = 0$$

$$\therefore I = \frac{1}{R} E$$

$$I = EG = VG$$

$$G = \frac{\Delta I}{\Delta V}$$

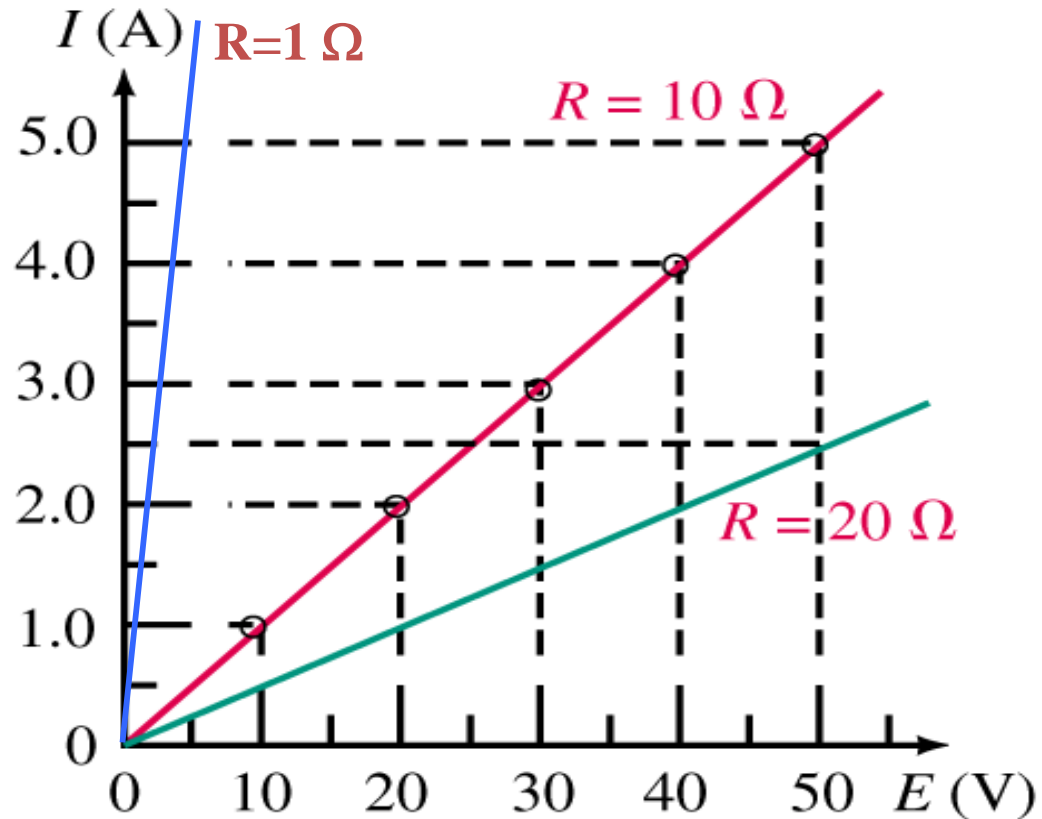

The resistance can be found at any point on the plot since a straight line indicates a fixed resistance.

$$\text{Slop} = m = \frac{\Delta I}{\Delta V} = \frac{1}{R} = G$$

$$m = \frac{\Delta V}{\Delta I} = \tan(\theta) = R$$

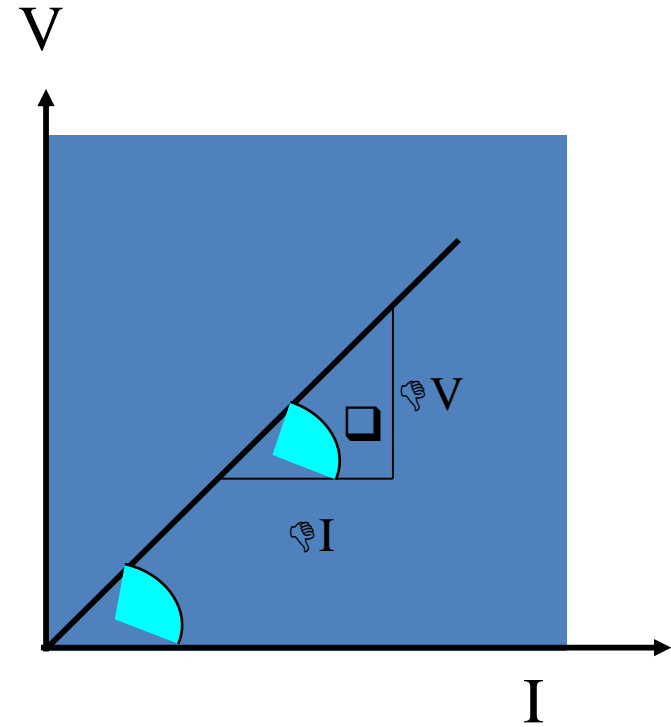
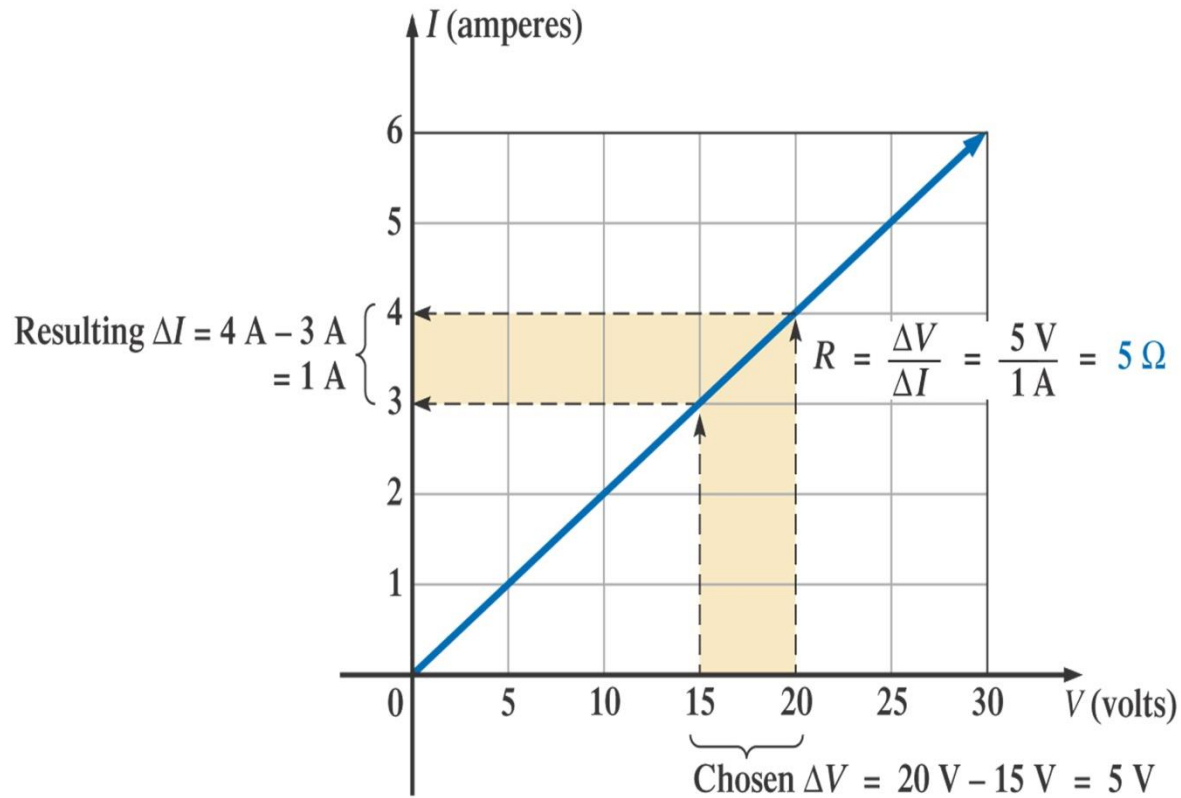

Less the resistance, the steeper the slop (closer to I axis)

How many amperes of current are in the circuit of Figure

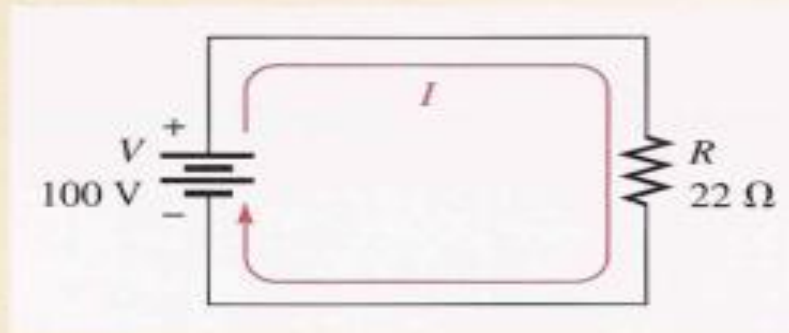

Solution Use the formula $I = V/R$, and substitute 100 V for V and 22Ω for R .

$$I = \frac{V}{R} = \frac{100 \text{ V}}{22 \Omega} = 4.55 \text{ A}$$

Calculate the current in Figure :

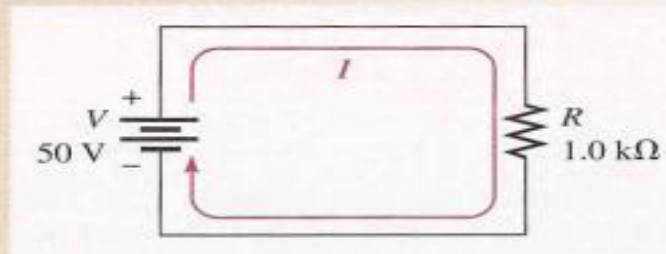

Solution Remember that $1.0 \text{ k}\Omega$ is the same as $1 \times 10^3 \Omega$. Use the formula $I = V/R$ and substitute 50 V for V and $1 \times 10^3 \Omega$ for R .

$$I = \frac{V}{R} = \frac{50 \text{ V}}{1.0 \text{ k}\Omega} = \frac{50 \text{ V}}{1 \times 10^3 \Omega} = 50 \times 10^{-3} \text{ A} = 50 \text{ mA}$$

In the circuit of Figure 1: how much voltage is needed to produce 5 A of current?

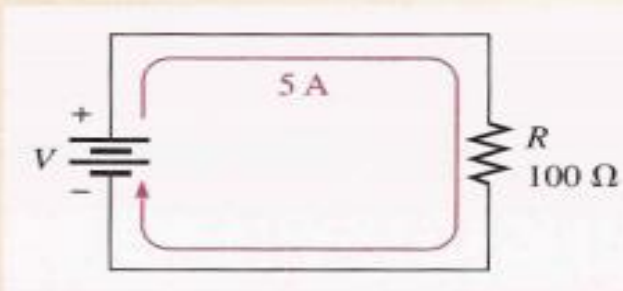

Solution Substitute 5 A for I and 100Ω for R into the formula $V = IR$.

$$V = IR = (5 \text{ A})(100 \Omega) = \mathbf{500 \text{ V}}$$

Thus, 500 V are required to produce 5 A of current through a 100Ω resistor.

How much voltage will be measured across the resistor in Figure 2?

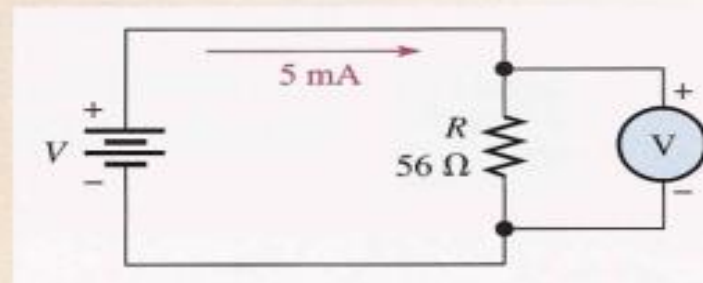

Solution Five milliamperes equals 5×10^{-3} A. Substitute the values for I and R into the formula $V = IR$.

$$V = IR = (5 \text{ mA})(56 \Omega) = (5 \times 10^{-3} \text{ A})(56 \Omega) = 280 \times 10^{-3} \text{ V} = \mathbf{280 \text{ mV}}$$

When you multiply milliamperes by ohms, you get millivolts.

In the circuit of Figure 1, how much resistance is needed to draw 3.08 A of current from the battery?

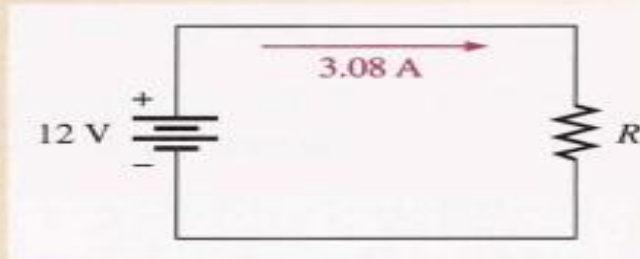

Solution Substitute 12 V for V and 3.08 A for I into the formula $R = V/I$.

$$R = \frac{V}{I} = \frac{12 \text{ V}}{3.08 \text{ A}} = 3.90 \Omega$$

Suppose that the ammeter in Figure 2 indicates 4.55 mA of current and the voltmeter reads 150 V. What is the value of R ?

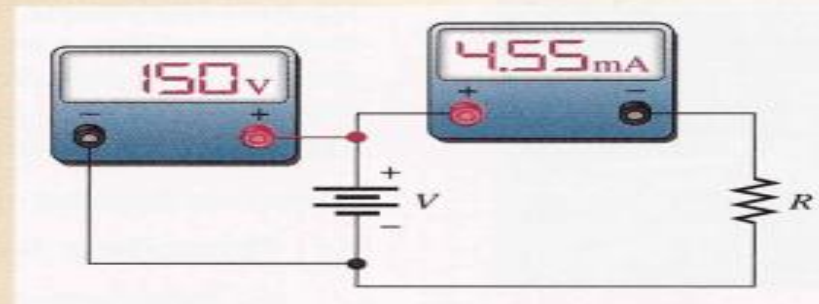

Solution 4.55 mA equals 4.55×10^{-3} A. Substitute the voltage and current values into the formula $R = V/I$.

$$R = \frac{V}{I} = \frac{150 \text{ V}}{4.55 \text{ mA}} = \frac{150 \text{ V}}{4.55 \times 10^{-3} \text{ A}} = 33 \times 10^3 \Omega = 33 \text{ k}\Omega$$

When volts are divided by milliamperes, the resistance is in kilohms.

Power in Electrical Systems

$$P = \frac{W}{t}, \quad p = \frac{dw}{dt} \text{ but } V = \frac{W}{Q} \rightarrow W = VQ \text{ electron volte : is the energy}$$

absorbed by R in the form of heat

$$dw = \int_{-\infty}^{\infty} p(t) dt \geq 0 \text{ If } i \text{ enters + ve terminal}$$

$$\therefore P = \frac{V}{t} Q = VI \text{ [watts, W, or joules / Second (J / s)]}$$

• From Ohm's Law, we can also find that

$$P = VI = V \frac{V}{R} = \frac{V^2}{R}$$

$$P = VI = IR * I = I^2 R \text{ (the power dissipated or absorbed)}$$

$$\text{if } i \text{ enters - ve terminal, } v = -Ri, P = \frac{V^2}{R} = +$$

Thus p(t) is nonlinear every time

1 horsepower hp = 746 watts

W=watt but energy is symbolized by *W italic*

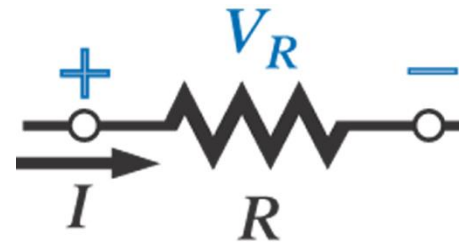
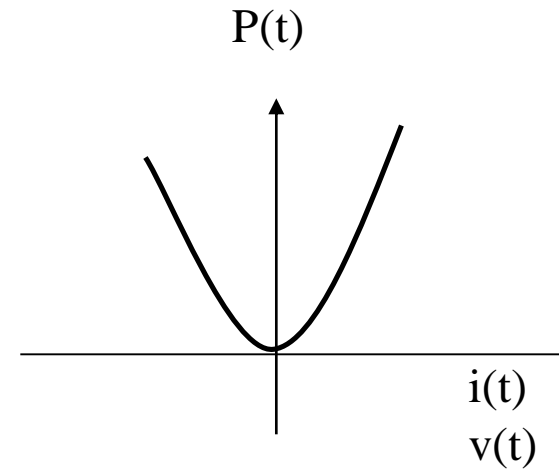

Last equation says that the power at a resistor is always positive

Resistors always absorb power.

$$i(t) = G V(t)$$

$$P(t) = v(t)i(t) = \frac{i(t)}{G} i(t) = \frac{i^2(t)}{G}$$

$$= v(t) i(t) = \frac{i^2(t)}{G} = G v^2(t)$$

Example

Find the power delivered to the dc motor in the figure

$$P_{\text{in}} = EI = IV = (120\text{V})(5\text{A}) \\ = 600\text{W} = 0.6\text{kW}$$

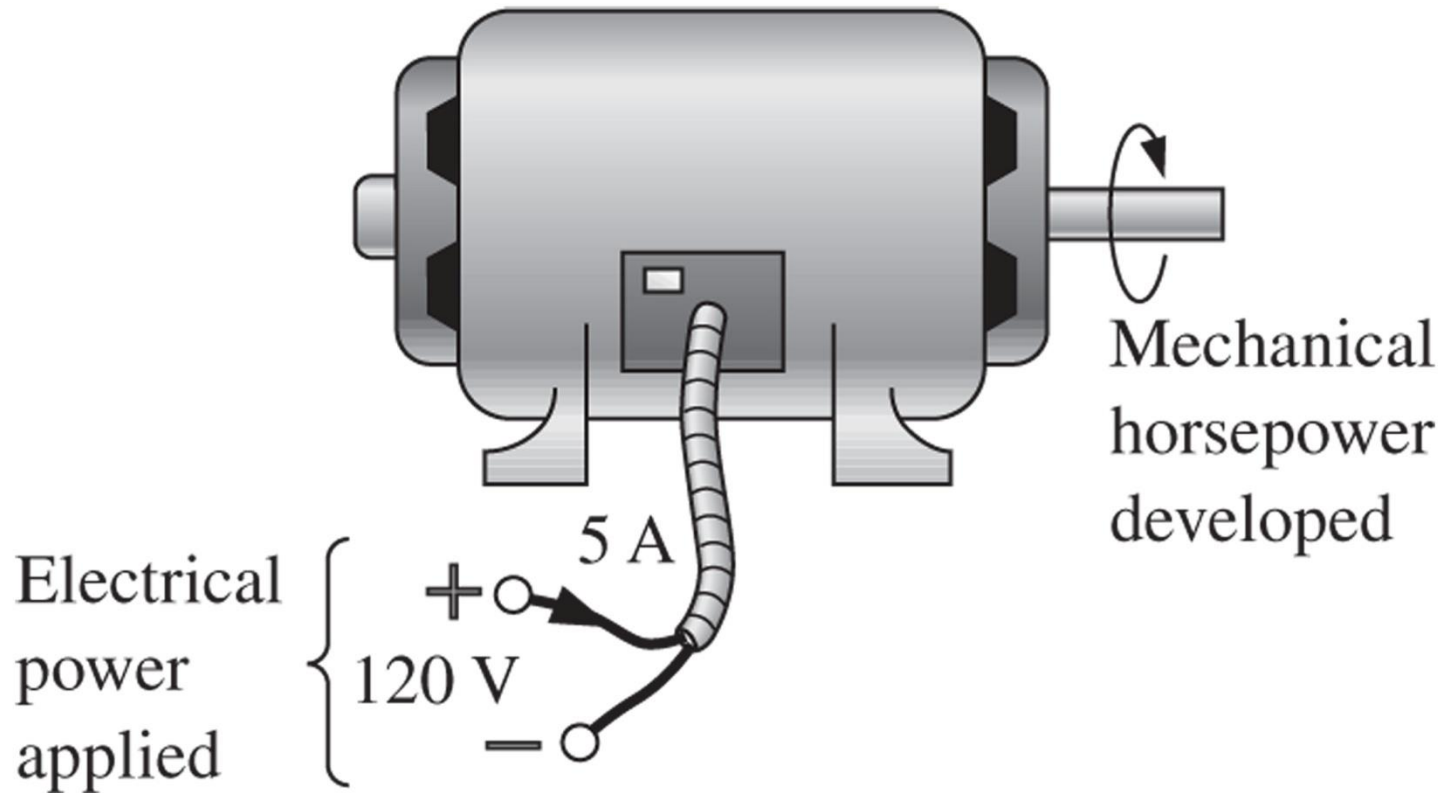

Active Elements:

There are 4 types of active elements (sources):

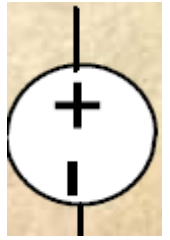

1. Independent voltage source:

It is a 2-terminal sources that maintains a specific voltage across its terminals regardless of the current through it.

2. Independent current source:

It is a 2-terminal sources that maintains a specific current through it regardless of the voltage across it terminals.



3. Dependent voltage source:

It is a 2-terminal sources that generates a voltage that is determined by a voltage or current at a specified location in the circuit.



4. Dependent current source:

It is a 2-terminal sources that generates a current that is determined by voltage or current at a specified location in the circuit.



Notation

Plays an important role in the cct analysis
Voltage sources and grounds

Grounds

Electrical and electronic systems are grounded for reference and safety purposes

Below we show some common symbols for common or ground.

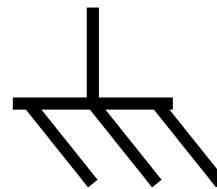
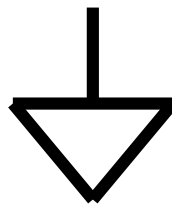
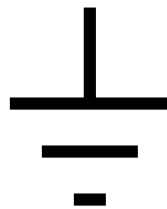

0 V

Ground symbol

Voltage sources

Notation

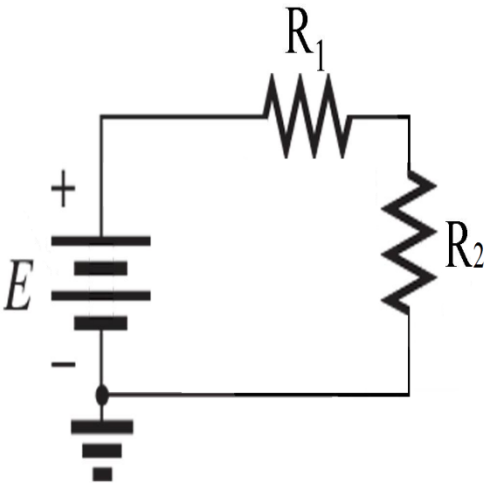

a

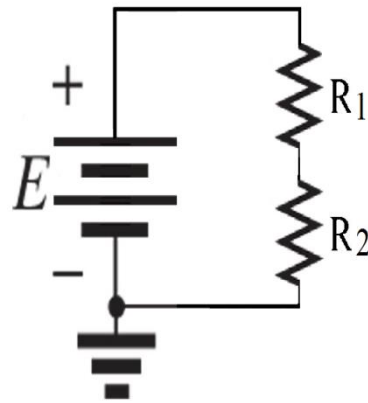

b

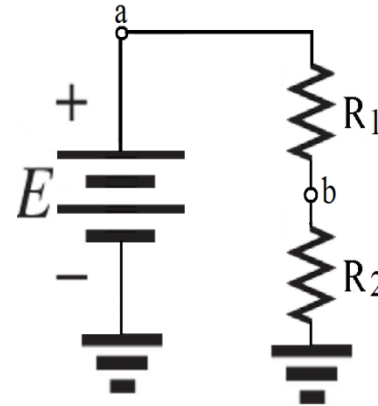

c

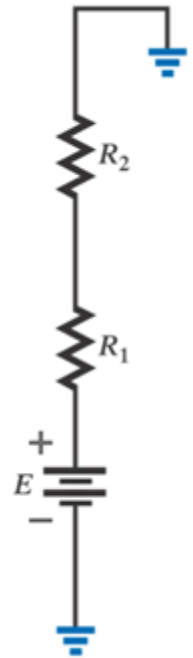

d

- If $E=12$ v, then a is 12 V positive wrt ground, and 12 V exist across the R_1+R_2

Notation

Voltage sources on large schematics

Voltage source symbol

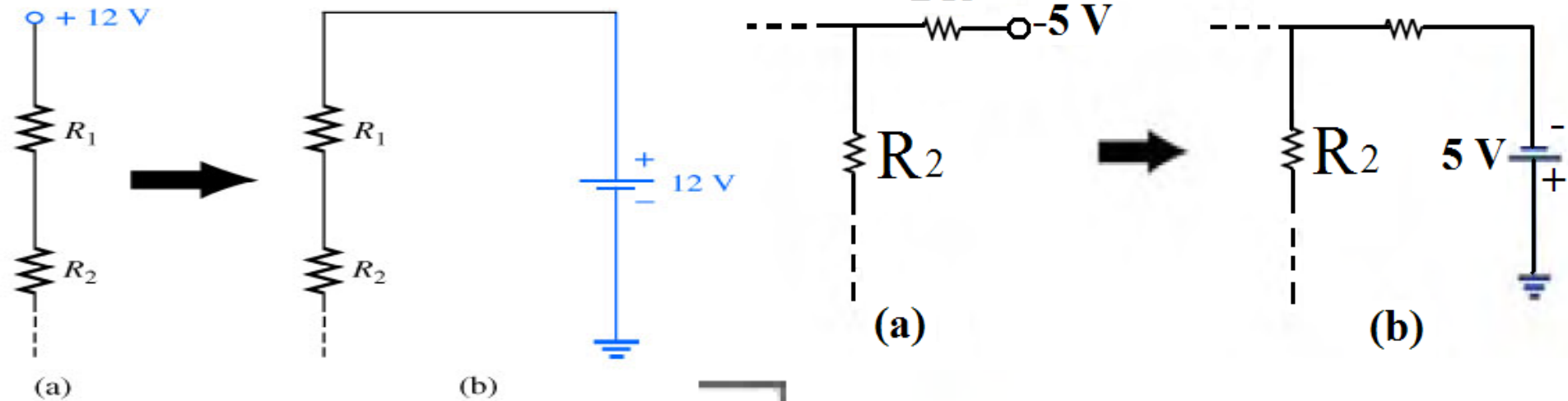

Voltage at a point

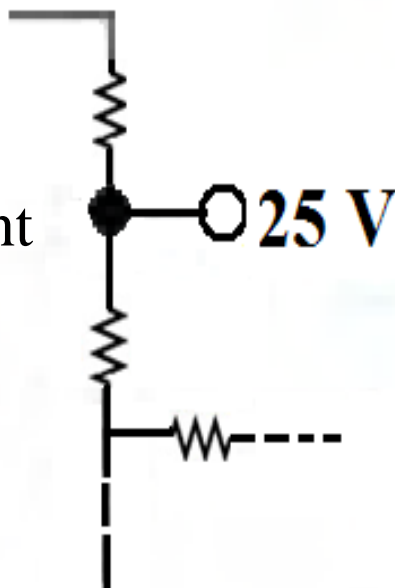

Notation

⌘ Double-subscript notation

- ⌘ Because voltage is an “across” variable and exists between two points, the double-subscript notation defines differences in potential.
- ⌘ The double-subscript notation V_{ab} specifies point a as the higher potential. If this is not the case, a negative sign must be associated with the magnitude of V_{ab} .
- ⌘ The voltage V_{ab} is the voltage at point (a) with respect to (wrt) point (b).

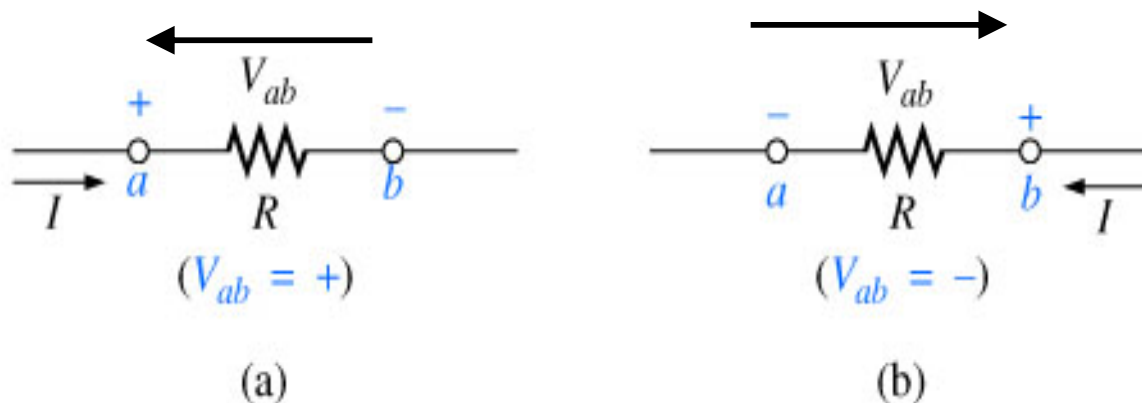

Notation

Single-subscript notation

- The single-subscript notation V_a specifies the voltage at point a with respect to ground (zero volts). If the voltage is less than zero volts, a negative sign must be associated with the magnitude of V_a .

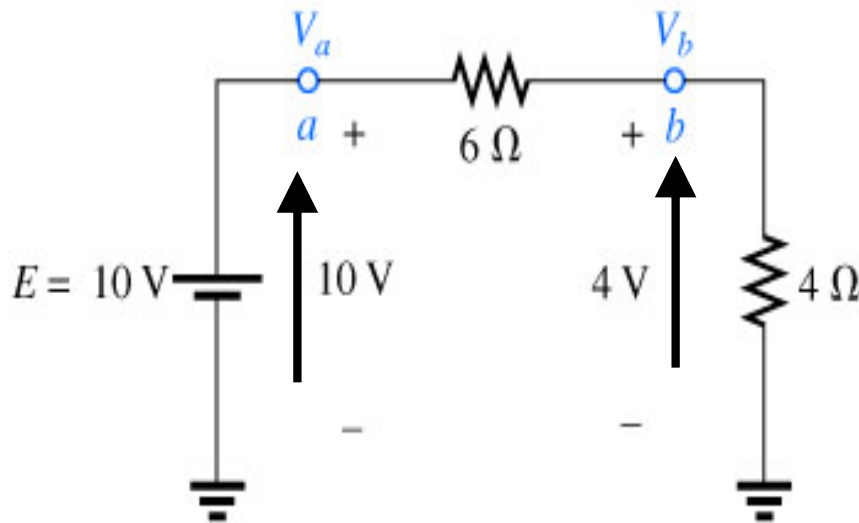

$$V_a = +10 \text{ V}$$

$$V_b = +4 \text{ V}$$

$$\therefore V_{ab} = 10 - 4 = 6 \text{ V}$$

Notation

⚡ General Relationship

⚡ If the voltage at points a and b are known with respect to ground, then the voltage V_{ab} can be determined using the following equation:

$$V_{ab} = V_a - V_b$$

$$\text{If } V_b = 0$$

Then $V_{ab} = V_a$ (Single - subscript notation)

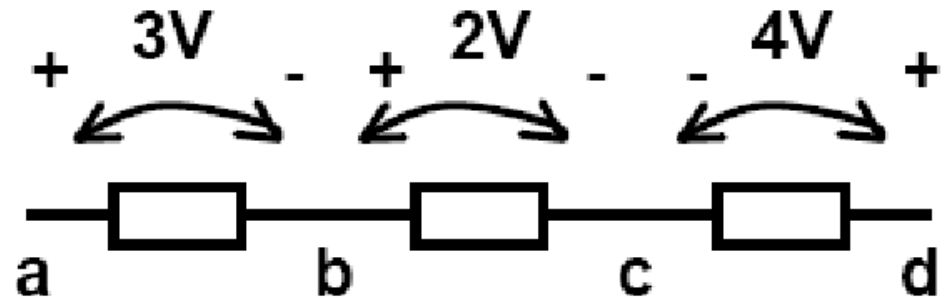

$$V_{ab} = 3V$$

$$V_{bc} = 2V$$

$$V_{cd} = -4V$$

$$V_{ab} = 3V$$

$$V_{ac} = 5V$$

$$V_{ad} = 1V$$

Find V_{ab}

$$V_{ab} = V_a - V_b = 16 - 20$$

$$= -4\text{V}$$

Find V_a

$$V_{ab} = V_a - V_b$$

$$5 = V_a - 4 \Rightarrow V_a = 9\text{V}$$

Find V_{ab}

$$V_{ab} = V_a - V_b$$

$$= 20 - (-15) = 35\text{V}$$

Ex

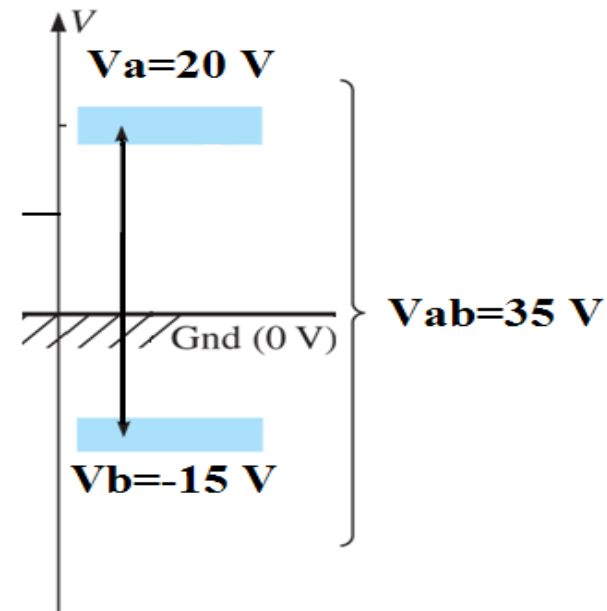
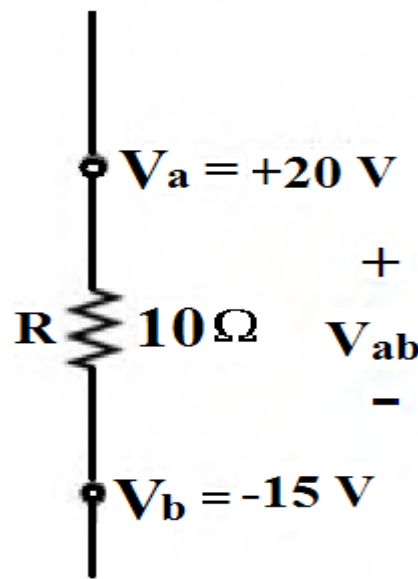
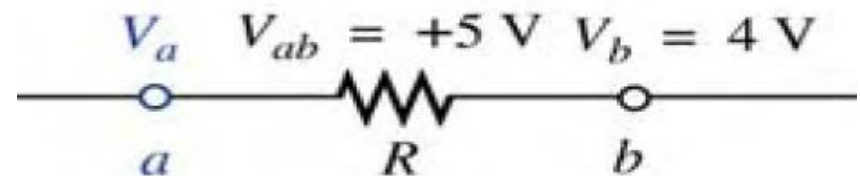
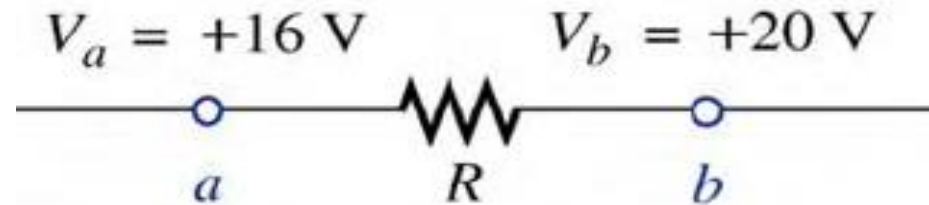

Find V_b , V_c & V_{ac}

$V_a = 10\text{ V}$ and $V_{ab} = 4\text{ V}$

$V_b = 10 - 4 = 6\text{ V}$

$V_c = V_b - 20 = 6 - 20 = -14\text{ V}$

$V_{ac} = V_a - V_c = 10 - (-14) = 24\text{ V}$

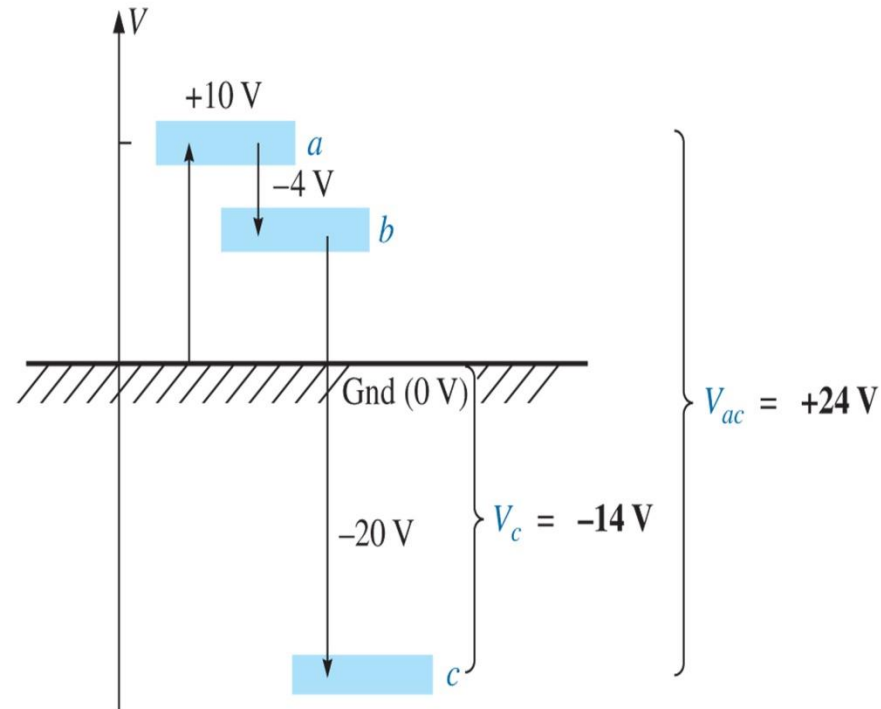
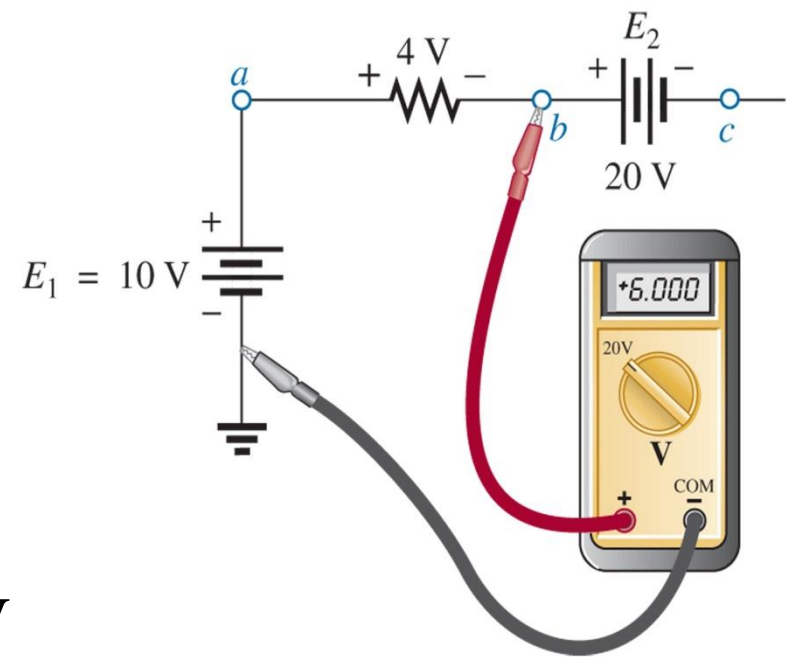

H.W

Find V_{ab} , V_{cb} & V_c

Note : when you redraw te cct the - sign of the sources will disappear

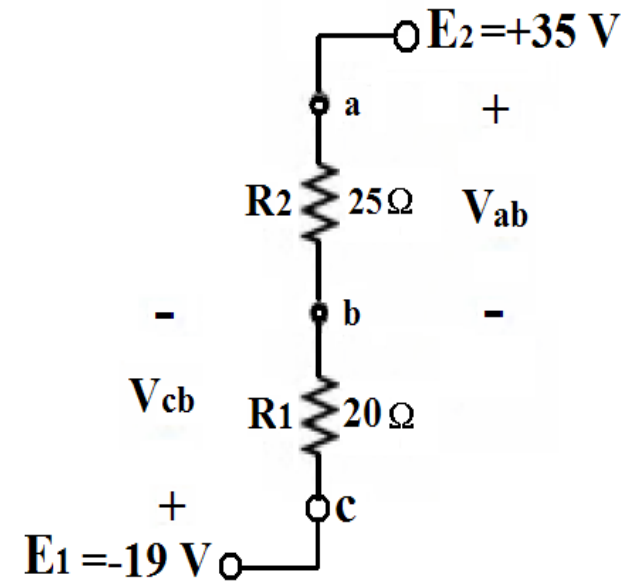

Find V_{ab} , V_b & V_c

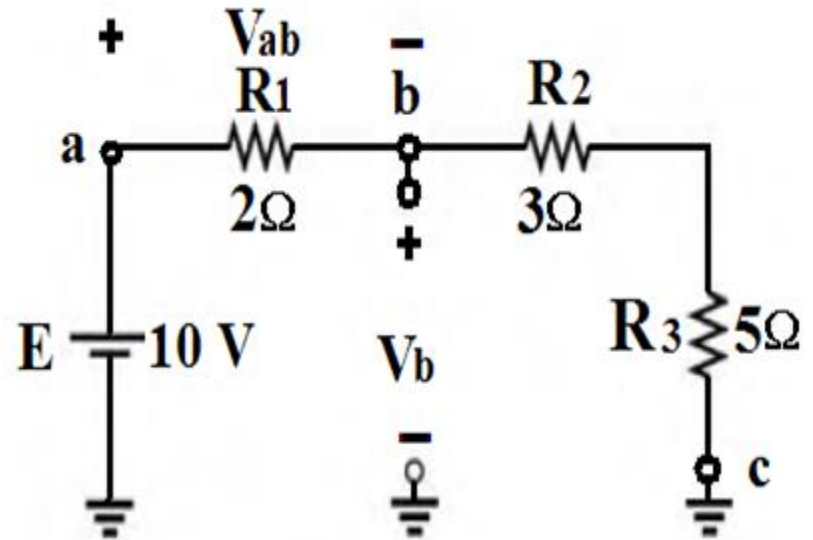

Ohm's law for a branch in a circuit

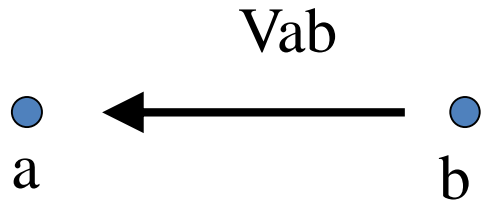

$$V_{ab} = +Ve \text{ if } V_a \succ V_b$$

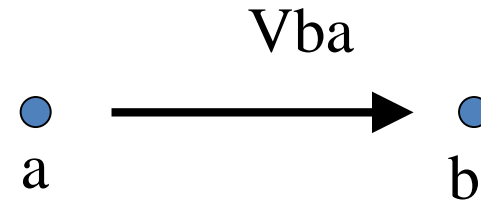

$$V_{ba} = +Ve \text{ if } V_b \succ V_a$$

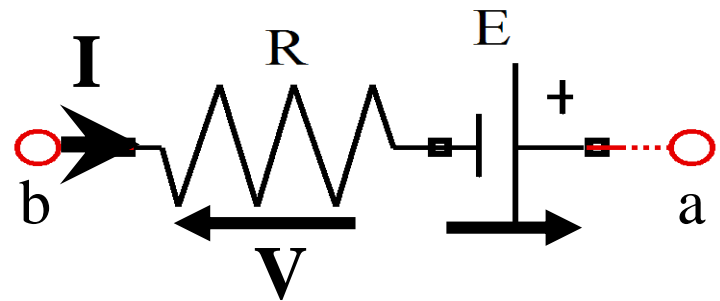

$$V_{ab} = -V + E$$

$$-IR + E$$

$$V_{ba} = -E + V$$

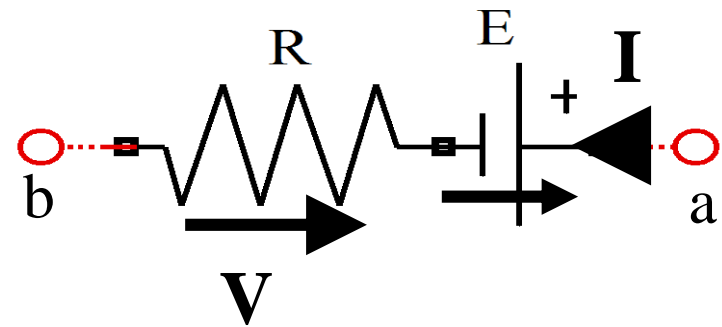

$$V_{ab} = V + E$$

$$= IR + E$$

$$V_{ba} = -V - E$$

Ex: Find V_{ab} & V_{ba}

$$V_{ab} = 15 - (2 * 5) \rightarrow V_{ab} = 5V$$

$$V_{ba} = (2 * 5) - 15 \rightarrow V_{ba} = -5$$

$$= -V_{ab}$$

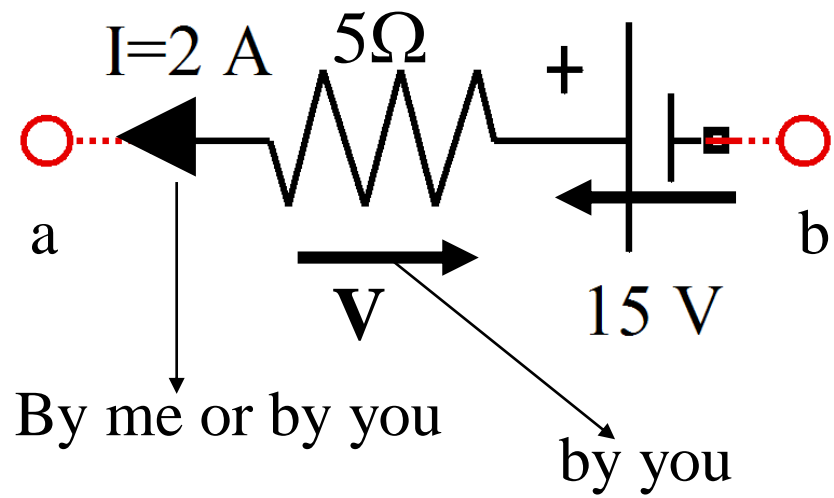

Ex: Find V_{ab} & V_{ba}

$$V_{ab} = 15 + (2 * 5) \rightarrow V_{ab} = 25V$$

$$V_{ba} = -(2 * 5) - 15 \rightarrow V_{ba} = -25$$

$$= -V_{ab}$$

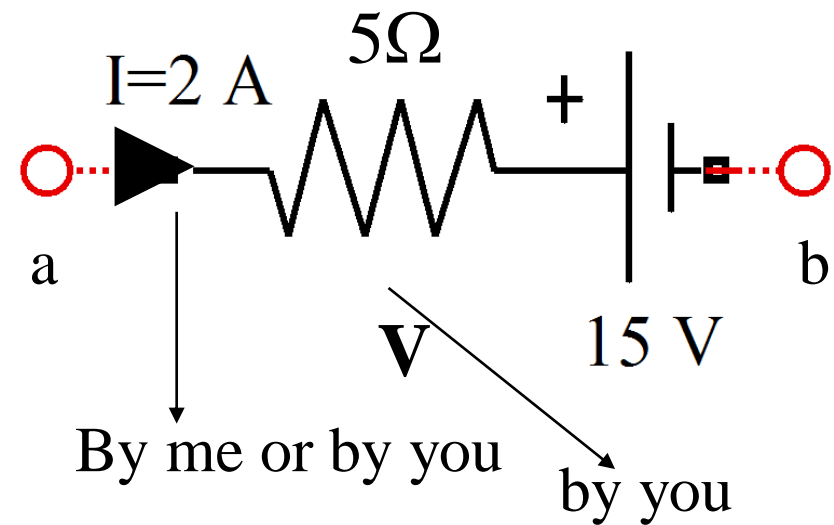

$$V_{AB} = V_A - V_B \text{ or } V_{BA} = V_B - V_A$$

Ex: Find V_{xy}

$$I_1 = \frac{E_1}{R_1} = \frac{10}{2} = 5A, I_2 = \frac{E_2}{R_2} = \frac{5}{5} = 1A$$

$$V_{xy} = I_2 R_2 + E_2 - (I_3 * R_3) + I_1 R_1$$

$$V_{xy} = 5 + 20 - (0 * 6) + 5 * 2 = 35V$$

