

EXP. No (6)

Determine the Transmission Line Parameters by ABCD Constants

Object:

To find experimentally the magnitude and angle of each of the four general constants of T.L.

The relationship between the parameters of the four terminal work is:

$$V_s = A V_r + B I_r \quad \text{-----} \quad (1)$$

$$I_s = C V_r + D I_r \quad \text{-----} \quad (2)$$

Where:

$$A = |A| \angle \alpha$$

$$B = |B| \angle \beta$$

$$C = |C| \angle \theta$$

$$D = |D| \angle \delta$$

Procedure:

1- To determine the constant of (A):

- a- Connect the circuit diagram as shown in the fig (1), no load test.
- b- Read the value of (V_s , V_r , and V_{drop}).
- c- Calculate the magnitude of A as:

$$|A| = \frac{|V_s|}{|V_r|} \quad \text{-----}$$

And its angle from the plot as:

$$\alpha = \angle A \quad \text{-----}$$

2- To determine the constant of (B):

The receiving end should be short circuited as shown in fig (2) and read V_s , I_s and P.

And the angle (β) is determined as:

$$P_s = V_s I_r \cos \beta \quad \text{-----}$$

And hence B can be determined as:

$$|B| = \frac{|V_s|}{|I_r|} \quad \text{-----}$$

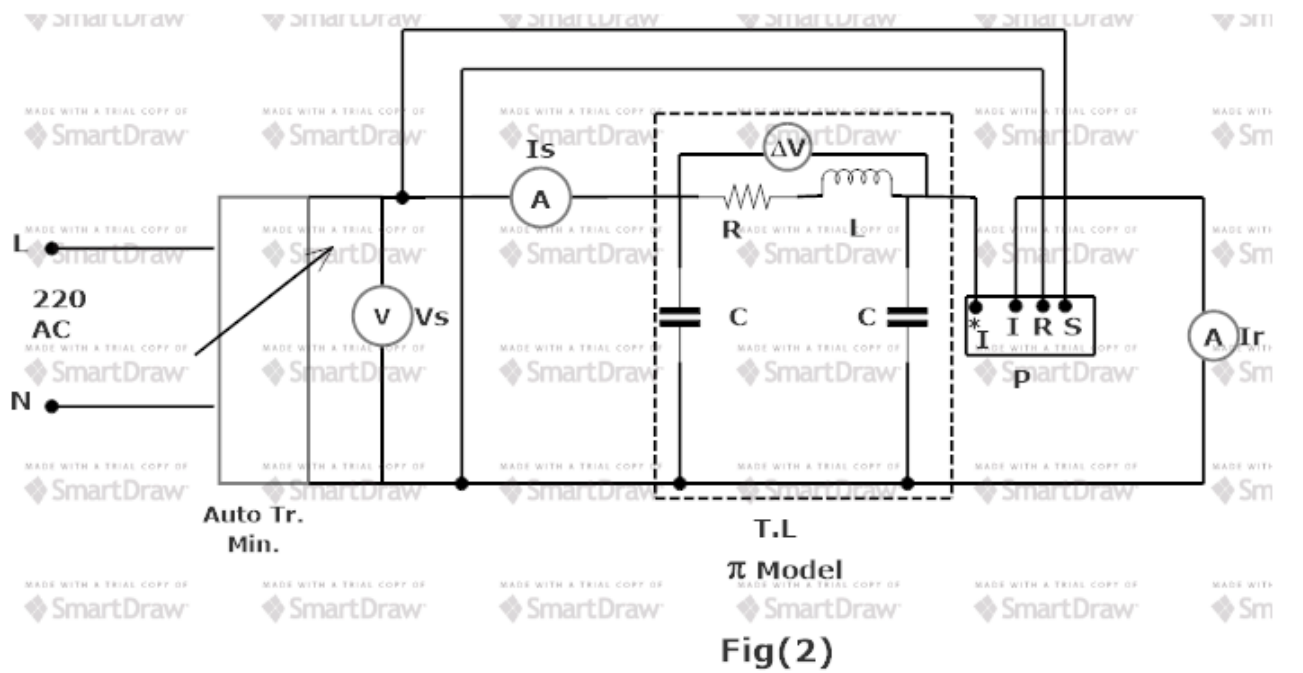
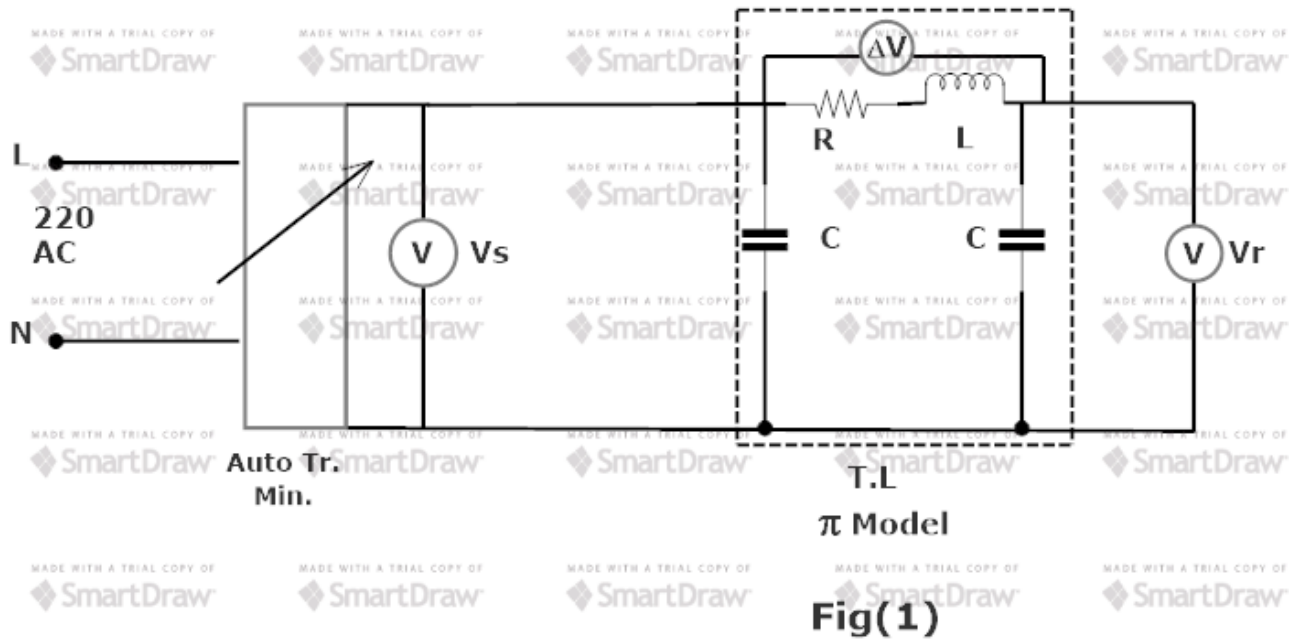

3- To determine the constant of (C):

a-Connect the circuit as shown in fig (3), (no load test) but introducing the wattmeter as shown in the diagram. Read the meters and then calculate:

$$|C| = \frac{|I_s|}{|V_r|} \text{ -----}$$

To find θ : $P = V_s I_r \cos \theta \text{ -----}$

4- To determine the constant of (D):

In the transmission lines the constant D is identical as A:

Verify the relation:

$$AD - BC = 1 \text{ -----}$$

